

Instructions & Specifications: 24V Single Channel Remote Dimmer, 7A (168W @ 24VDC)

This dimmer is designed to operate LED and incandescent lighting operated on 24-28VDC. It uses a remote mounted rheostat for control of output loads using Pulse-Wave Modulation (PWM) to provide precise dimming.

To install, use the screw terminals to attach input and output wires to the dimmer module. Mount the remote rheostat and route and connect the color coded wires to the dimmer module (shaft diameter is 0.267" (17/64")(6.75mm)). Use a properly rated fuse between the dimmer module and power source. Take care to ensure the dimmer module does not contact surrounding metal structure or other wiring. Use stand-offs (not included) or zip ties to secure the dimmer module where desired. Under heavy load, ensure the dimmer heat sink has adequate ventilation to prevent overheating.

Specifications

Mode of Operation - Continuously variable, pulse width modulation (PWM). 100hz operating frequency

Supply Voltage—20 to 28VDC working voltage. When input voltage is larger than 30VDC, output will be turned off. When the input voltage drops to less than 30 VDC, the dimmer will reset to normal work.

Output Voltage Range - From zero VDC to supply voltage

Output Current Range - Up to 7.0A per channel

Max Continuous Output Current - Full rated current up to 105 F (40C), 75% of rated current up to 115F (46C)

Ambient Temp Range - minus 40F (-40C) to 115F (46C), with restrictions as noted

DC-DC Conversion Efficiency - About 98% at full rated current, higher at lower current

Load Types - Optimized for resistive loads

Reverse Battery Protection - If input leads are reversed, the dimmer will not work. When the input leads are correctly connected, the dimmer will reset to normal work. Always use an external fuse to protect the dimmer and load.

Forward Transient Protection - Double resistive/capacitive filtering, zener diode clamping.

MCU will detect over voltage and over-current within less than 0.1 seconds

Voltage Drift - Nil

Size – 1.5" x 1.3" inch square

Weight - About 50 gm, depending on wired connection type

Load Regulation - Generally less than 3% from minimum load to maximum load at all settings

Line Regulation - Directly proportional to supply voltage

Power Dissipation of Drive Circuitry - Less than 0.1W. No load current draw is about 2mA.

The dimmer is controlled by MCU and provided with voltage regulation. When the dimmer is turned off, the power is not cut off completely. The power dissipation is still Less than 0.1W

Current Limiting - If light source current exceeds protected maximum of 7A per channel, the dimmer will stop functioning. To reset, remove input voltage momentarily. Be sure to fix the cause of overload before resetting.

Accessories – Large fluted knob (set-screw type), rheostat with color-coded wires and instructions

Wiring Diagrams

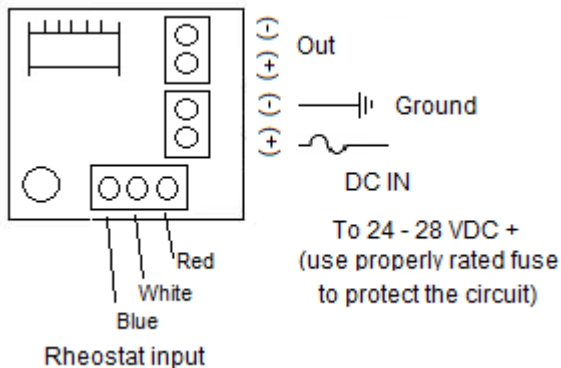

Applications: Autos, Trucks, Boating, RVs/Specialty Vehicles, Experimental Aircraft (note: this part is not PMA approved for certified aircraft)

Made in China

Mechanical Drawing:

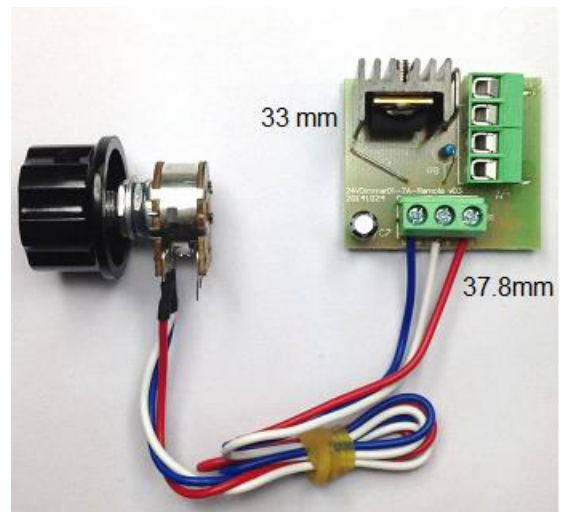

Britta Products LLC, Long Beach, CA -
www.pilotlights.net -

Part number: 24VDimmer01-7A-REMOTE